



5000/6000 SERIES BALL VALVES INSTALLATION - MAINTENANCE MANUAL

DESIGN

The design features three piece construction and a “free floating” ball allowing ease of maintenance without special tools.

The ball is not fixed, but is free to move with the line pressure. These valves are capable of tight shut-off with flow in either direction regardless of the position of the valve in the line.

The downstream seat, opposite the pressurized side of a closed valve, must carry the load exerted by the line pressure on the ball, while the upstream seat is subject to little load or wear. For this reason, it is sometimes possible to increase useful seat life by turning the valve end-for-end in the pipeline.

1. USE:

The valve should be inspected regularly as part of a preventative maintenance program. Flow-Tek’s recommended pressure, temperature and corrosion limits should be followed to ensure a long service life. During shipment, storage, and in operation, the valve should be fully open or fully closed (“open” is preferred for shipping and storage). Do not use in throttling service without investigating the consequences of flow and pressure conditions to the valve.

WARNING: Before installing this equipment, confirm that it is suitable for the intended service.

The identification tags describe the maximum allowable service conditions for this product.

Be sure that the installation is protected by appropriate pressure control and safety devices to ensure that acceptable limits are not exceeded.

2. OPERATION:

Operation of the valve is by turning the handle a 1/4 turn (90 degrees). CW to close, CCW to open.

A. VALVE OPEN POSITION

The handle is parallel with the pipeline.

B. VALVE IN CLOSED POSITION

The handle is perpendicular to the pipeline.

Valves with actuators should be checked for actuator -valve alignment. Misalignment will result in high operational torque and damage to valve stem and seals.

STEM SEAL ADJUSTMENT:

Stem seal leakage may be corrected without disassembly by tightening the packing gland nut gradually until the leakage stops. If the leakage continues after adjustment or the valve operating torque becomes excessive, the seals are worn and should be replaced.

3. GENERAL INFORMATION FOR ON-SITE INSTALLATION:

Please read completely and understand all instructions provided prior to beginning installation or maintenance.

The pipes must be flushed clean of dirt, burrs, and welding residues before installing the valve, or the seats and ball surface will be damaged.

The valve may be installed in any position on the pipeline. Care should be taken to insure that actuator misalignment does not occur or the valve may experience premature failure. The actuator may require support to avoid binding the valve stem.

The pipe ends must be correctly aligned and spaced as to not induce stresses in the valve.

As shipped from the factory, Valves may contain non-silicone lubricant. This is for break-in and may be removed by solvent washing, if it is undesirable in a particular application.

INSTALLATION OF THREADED END VALVES:

1. The use of a thread sealant is recommended; Use conventional sealant, such as hemp core, Teflon, etc;
2. Do not tighten by applying torque to the opposite end cap or other valve components. Apply a wrench only to the hex/octagon nearest the valve



end being tightened. Tightening by using the valve body, handle or the opposite end cap can seriously damage the valve; Use a wrench on both the second end cap and pipe to avoid applying torque to the body through the bolting.

3. In some applications, threaded end valves may be back-welded on site. Use caution. Do not overheat the valve body. Confirm that the end cap bolt holes are aligned with the body screw holes on both ends and that the end caps are parallel and correctly spaced to fit the valve body before re-assembly or back welding. Make up both of the threaded connections normally and then remove the body assembly as described below for weld-end connections before back welding the threaded connection.
4. Do not use the body screws to pull the pipe ends together to correct misalignment.

INSTALLATION OF WELD-END VALVES

Insure that weld procedures are implemented that are compatible with the materials used.

1. Tack weld the assembled valve to the pipe at four points on both end caps.
2. With the valve in open position, (the valve is in the open position when the handle is parallel to the axis of the valve and pipe), loosen all body bolts, take the body out.
3. Turn the handle in the half open position. Remove the seats and body gaskets.
4. Turn handle in closed position and remove ball.
5. Place all removed parts in a clean and secure place.
6. Replace the body and all bolts and tighten them slightly. This operation is very important, so that the body and end caps remain perfectly parallel, thus preventing any leakage at the body joint after welding.
7. Finish welding both end caps onto the pipe. Use temperature indicating crayons to insure that the body temperature doesn't exceed 200°F in the area of the neck or component/seal damage may occur.
8. When cool, remove the body, clean the end caps, and reassemble per the instructions given below.
9. Place the bodies between the two end connections;

then replace all bolts and cross tighten.

10. (See table 1. Tightening torques for end cap screws).

4. DISASSEMBLY & CLEANING PROCEDURES:

CAUTION: Line must be depressurized before disassembly. Valve should be cycled after draining the system to relieve any pressure trapped in the valve body cavity. Ball valves can trap pressurized media when closed. Flush line with the valve 1/2 open to remove hazardous media. If the valve has been used to control hazardous media, it must be decontaminated before disassembly.

WARNING: DO NOT attempt to remove packing components or any other valve parts while line is under pressure!

CAUTION: Properly support the valve before removing or loosening any body bolts. The larger sizes are heavy and may cause injury if allowed to swing or fall freely.

Remove the actuation air and power connections and confirm that there is no stored energy in the actuation such as compressed springs or trapped air before beginning. Stored energy devices can cause serious injury if the energy is released without warning.

DISASSEMBLY FOR STEM AND SEAL SERVICE:

1. It is not necessary to remove the flanges from the pipeline. Removing the actuation and controls may make service easier.
2. Remove one of the upper body bolts and loosen the remaining bolts. The center body section containing the ball and seals will swing out for service, leaving the end caps in place on the pipe ends. See illustration below.
3. To completely remove the valve from the pipeline, remove the remaining upper body bolt and the body will lift free. Gently support the body in a vise to complete the remainder of the disassembly. To avoid damage to the seal surfaces, hold the body horizontally across its diameter, not across the end faces.
4. Remove the seats and body seals.
5. Remove the handle nut and handle. Remove the gland nut.
6. To remove the ball, rotate the stem so the ball is fully



closed. Lift the ball from body, using a strap and lift device if necessary.

NOTE: Extreme caution should be taken to avoid damage to the ball.

- The stem must be removed from inside the body - a tap on the top of the stem should loosen it. The thrust washer should come out with the stem. Then remove the stem packing.

Disassembly for servicing seats and stem seals may be performed without removing the end flanges from the pipeline.

This feature allows the removal of the valve from service without disturbing piping connections.

5. VISUAL INSPECTION:

Clean and inspect all metal parts for damage and wear. It is not necessary to replace the ball and stem unless the sealing surfaces have been damaged by abrasion or corrosion. Replacement of all soft parts is strongly recommended whenever the valve is disassembled for reconditioning. This is the surest protection against leakage. The replacement parts can be ordered in kit form.

NOTE: The valve may be assembled and operated dry where no lubricants are allowed in the system; however, a light lubrication of mating parts will aid in assembly and reduce initial operating torque. Any lubricant used must be compatible with the intended line fluid.

6. RE-ASSEMBLY:

Refer to the illustrations on page 4 and 5.

- Hold the body horizontally in a vise firmly enough that it will not move but do not crush it.
- Put thrust washer (12) on valve stem (5) and slide the stem into the stem hole from inside the valve body (1);

- Slide the stem packing components (14) onto the stem until they are bottomed in the stem hole;
- Install the packing gland nut (15) into the body over the stem and packing. Tighten finger tight.
- Turn the stem until the upper stem flat is perpendicular to the valve centerline (closed, so that the ball can fit onto the stem):
- Install the ball (3) inside the valve body. The lower stem flats will fit into the slot in the ball;
- Turn the stem so that the ball is in the open position (the ball will not fall out of the valve);
- Install the seats (4) and body seals into the body ends. Make sure the spherical curvature side of the seat will face the ball;
- Lift the valve into position between the flanges in the pipeline. Use caution that the seal components do not shift position or fall out.
- Install the end cap bolts (9), lock washers (7) and nuts (8). Alternately cross tighten all nuts gradually up to the values indicated in Table 1. Using a torque wrench is recommended.
- Install and secure the handle (25) with the handle washer (19) and handle nut (26).
- Cycle the valve slowly several times. Cycling the valve slowly will insure that the seats will align with and conform to the ball. A fast turning motion may damage the seats before they have a chance to form the proper seal:

Refer to the instructions given in section 2, above, to re-commission the valve after installation.

For automated installations, follow the instructions provided with actuation instrumentation to correctly set up and recalibrate the installation.

Table 1 - Tightening torques for end cap nuts

| VALVE SIZE | 1/4" | 3/8" | 1/2" | 3/4" | 1" | 1-1/4" | 1-1/2" | 2" | 2-1/2" | 3" | 4" |
|-------------------|------|------|------|------|-----|--------|--------|----|--------|----|----|
| NutTorque (lb-in) | 70 | 70 | 155 | 155 | 155 | 300 | 300 | | | | |
| (Lb-ft) | | | | | | 25 | 25 | 43 | 58 | 83 | 83 |



COMPONENTS

| Item | Name | Qty. |
|------|------------------|------|
| 1 | Body | 1 |
| 2 | End Cap | 2 |
| 3 | Ball | 1 |
| 4 | Seat | 2 |
| 5 | Stem | 1 |
| 6 | Body Seal | 1 |
| 7 | Washer | * |
| 8 | Body Nut | * |
| 9 | Body Bolt / Stud | ** |
| 12 | Thrust Washer | 1 |
| 14 | Stem Packing | 1 |
| 15 | Gland Nut | 1 |
| 19 | Handle Washer | 1 |
| 23 | Stop Set Sleeve | 1 |
| 24 | Stop Bolt | 1 |
| 25 | Handle | 1 |
| 26 | Handle Nut | 2 |
| 28 | Handle Sleeve | 1 |
| 29 | Locking Device | 1 |

* Number of Nuts & Lock Washers:
1/4" - 2" Valves 4
2-1/2" - 3" Valves 8
4" Valves 12

** Number of Body Bolts or Studs:
1/4" - 2" 4 (Bolts)
2-1/2" - 3" 4 (Studs)
4" Valves 6 (Studs)

1/4" - 2" Valves

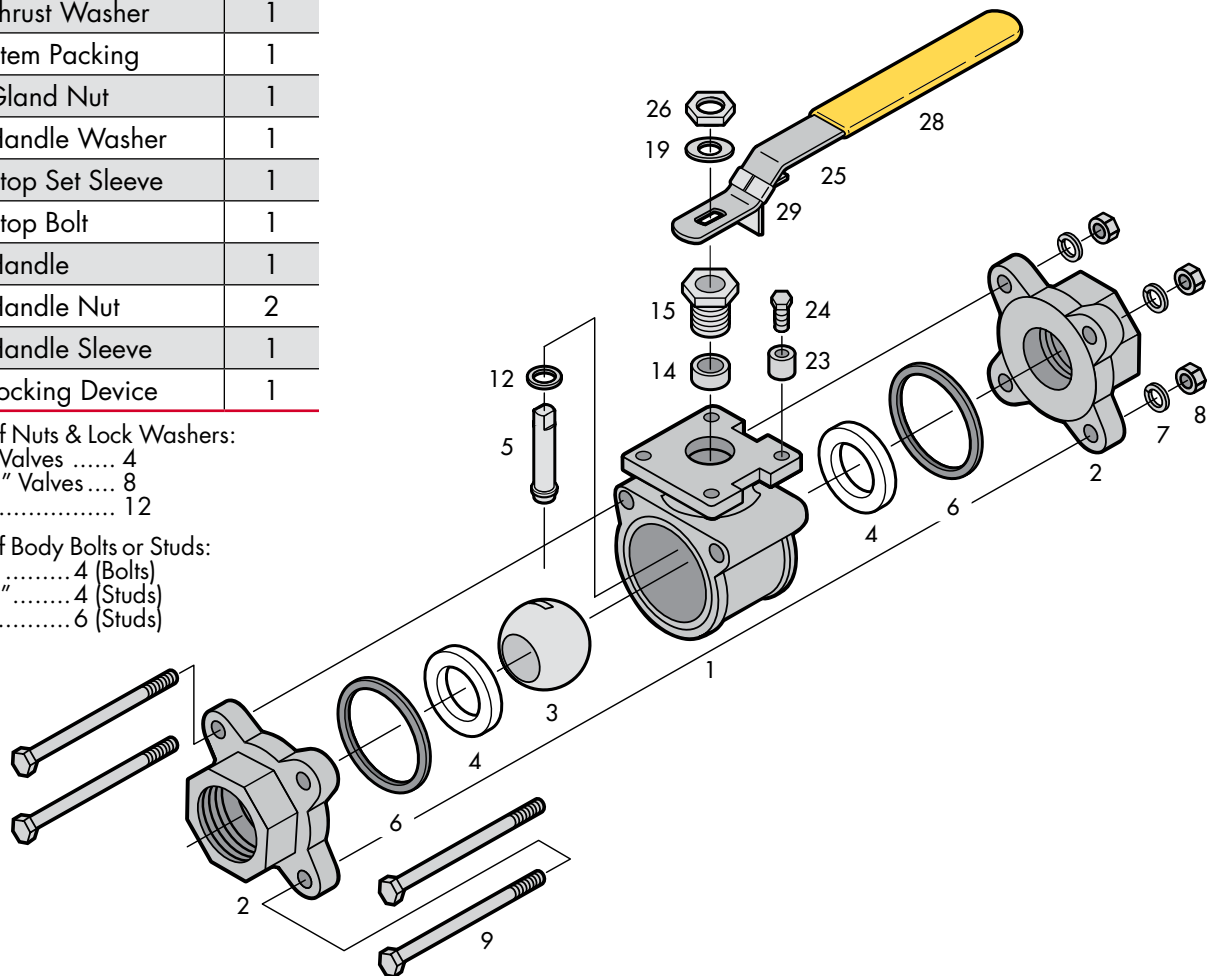



8. Short and Long Term Storage:

Short term:

1. Short term storage is defined as storage of products and equipment to be used in the construction of a project for periods of one to three months.
2. Ball valves should remain in the original shipping containers be placed on pallets of wood or other suitable materials. End protectors should remain on the valve ends to prevent the entrance of dirt.
3. Valves should be stored in the open position to protect the ball and seats.
4. Storage of ball valves can be in an open uncovered area provided provisions are made for inclement weather such as tarps or sheeting. Valves with electric actuators shall be stored under cover until ready for installation.

Long term:

1. Long term storage is storage of products and/or equipment for periods of three months or more.
2. Valves should be stored in the open position to protect the ball and seats.
3. Ball valves should remain in the original shipping containers placed on pallets of wood or other suitable materials and stored indoors. End protectors should remain on the valve ends to prevent the entrance of dirt. The storage environment should be dry and not have severe swings in temperature and humidity.

9. Safety Summary

1. Read completely and understand all instructions provided prior to beginning installation or maintenance.
2. Follow all instructions as described using the correct tools for the job.
3. Before installing this equipment, confirm that it is suitable for the intended service. The identifications tags describe the maximum allowable service conditions for this product.
4. Be sure that the installation is protected by appropriate pressure control and safety devices to ensure that acceptable limits are not exceeded.
5. Remove actuation air and power connections and confirm that there is no stored energy in the actuation such as compressed springs or trapped air before beginning. Stored energy devices can cause serious injury if the energy is released without warning.
6. Confirm that line pressure has been removed and that there is no pressure trapped within the valve prior to beginning service. Do not attempt to remove any packing components or other fittings before confirming that pressure has been completely removed!
7. Do not begin service work without proper tools and protective safety measures.
8. The work area should be clear of obstructions and other safety hazards.